

EXPANSION TANK CAN BE BULK HEAD MOUNTED THEN USE HOSE Ø75 943366 AND Ø16 952969

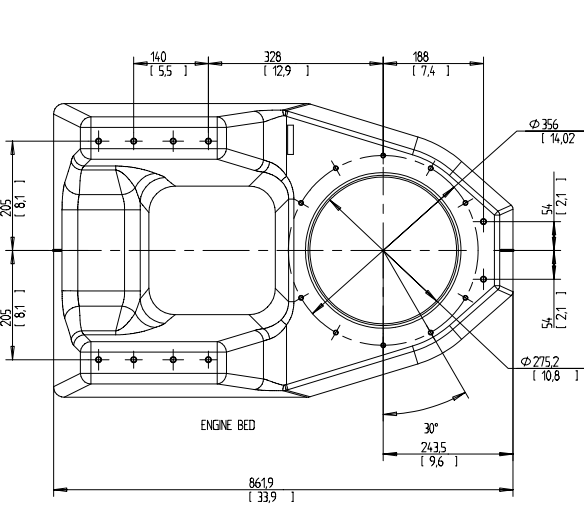
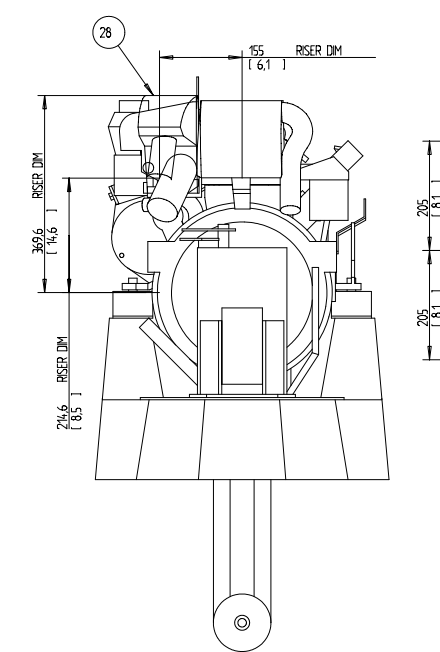
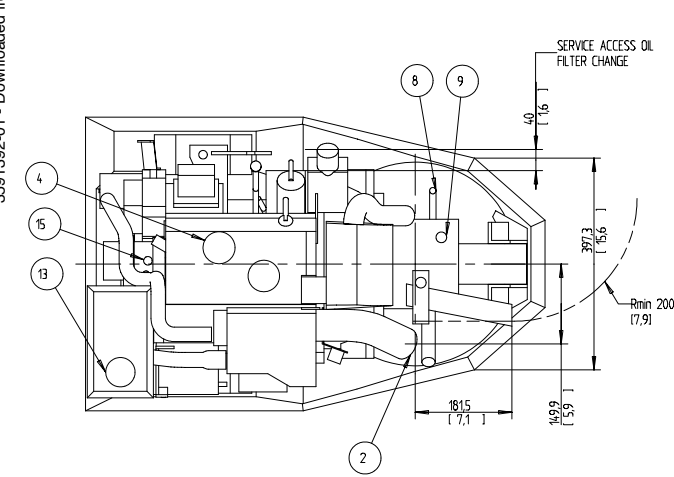
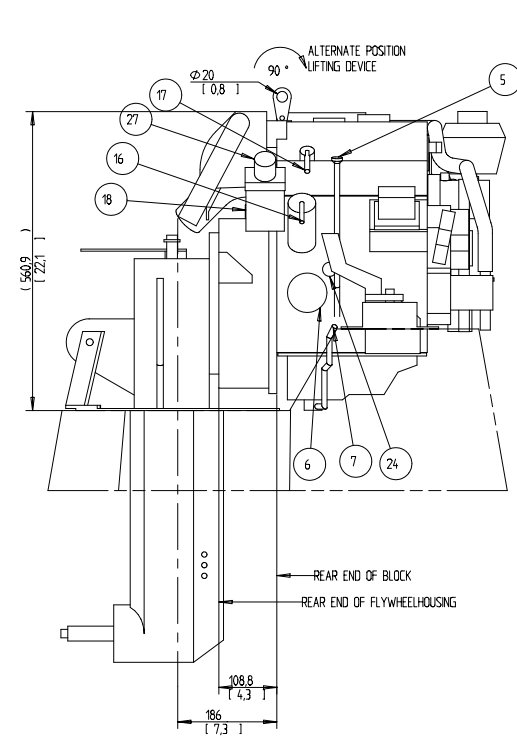
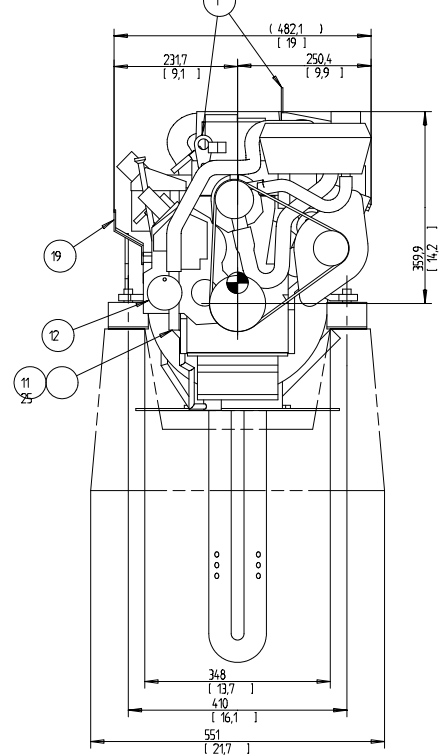
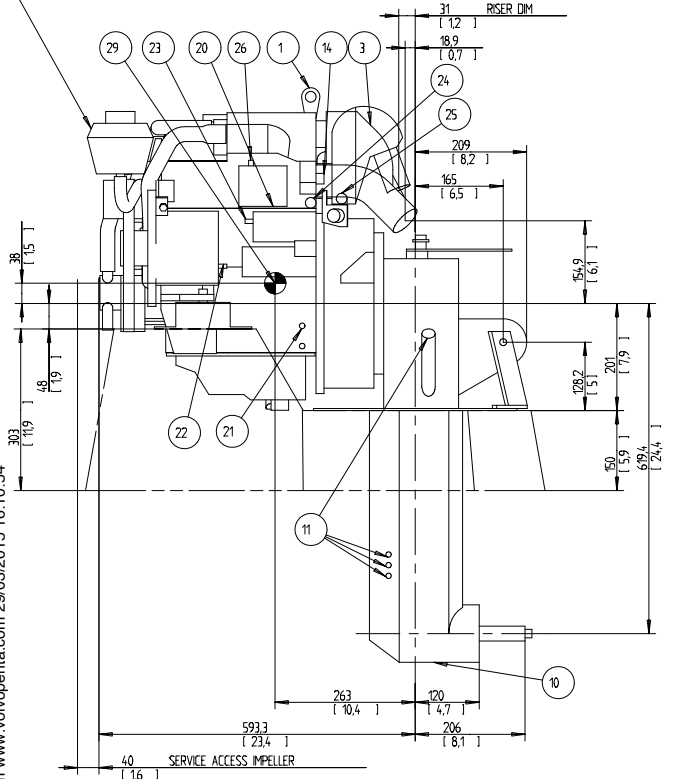

SCALE 1:5
OIL CAPACITY INCLUDING OIL FILTER: 35 LITERS
FRESHWATER SYSTEM CAPACITY: 4.1 LITERS
WEIGHTS:
DRY 154 kg
OIL & WATER 161 kg

DIMENSION IN MILLIMETRES AND (INCHES)

NR	ITEM
1	LIFTING DEVICE
2	EXHAUST ELBOW FOR HOSE ID 45(1.75)
3	AIR FILTER (SILENCER)
4	OIL FILLING
5	OIL DIPSTICK ENGINE
6	OIL FILTER
7	OIL DRAIN (WITH PUMP) ENGINE ID 8 10.35
8	OIL DIPSTICK REVERSE GEAR
9	OIL FILLER CAP REVERSE GEAR
10	OIL DRAIN REVERSE GEAR
11	SEA WATER INLET FOR HOSE ID 19(0.75)
12	SEA WATER PUMP
13	WATER FILLER CAP FRESH WATER
14	HOTWATER OUTLET
15	HOTWATER INLET
16	FUEL CONNECTION FOR HOSE ID 10 (3/8)
17	FUEL RETURN CONNECTION FOR HOSE ID 10 (3/8)
18	FUEL FILTER
19	SPEED CONTROL LEVER
20	CONNECTION BOX FOR EXTENSION CABLE
21	BATTERY MINUS (-) CONNECTION
22	PLUS (+) CONNECTION FOR CHARGING DISTRIBUTOR
23	STARTER BATTERY PLUS (+) CONNECTION
24	WATER DRAIN FRESH WATER
25	WATER DRAIN SEAWATER
26	AUTOMATIC FUSE RESET
27	HAND PRIMER PUMP
28	RISER (OPTIONAL)
29	CENTRE OF GRAVITY

3591392-01 - Downloaded from www.volvo-penta.com 29/03/2015 16:10:54